



# Resistance Prediction of the JBC Bulker using CFD Method



STUDENT: Cheng Xu  
SUPERVISOR: Prof. Robert Bronsart  
Dipl.-Ing. Lutz Kleinsorge  
REVIEWER: Prof. Pierre Ferrant

# CONTENTS

**1**

**OVERVIEW**

**2**

**THEORIES**

**3**

**CASE SETUP**

**4**

**MESH VALIDATION**

**5**

**JBC BULKER**

**6**

**CONCLUSIONS**

## Objective

Predict the total resistance and its components of JBC (Japan Bulker Carrier) bulker with the RANS method — OpenFOAM Solver

JBC Bulker



KVLCC2



main particulars		JBC	KVLCC2
Length between perpendiculars	$L_{PP}(m)$	280.0	320.0
Maximum beam of waterline	$B_{WL}(m)$	45.0	58.0
Depth	$D(m)$	25.0	30
Draft	$T(m)$	16.5	20.8
Block coefficient ( $C_B$ )		0.858	0.8098

## 1. Resistance Components

LTSInterFoam

simpleFoam

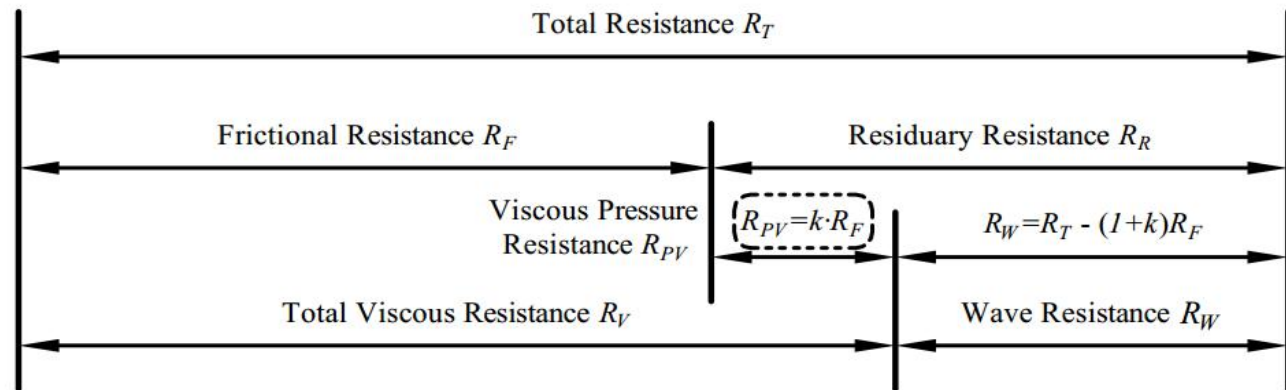

## 2. RANS Equation

Turbulent Model:  $k - \omega$  SST model

## 3. VOF (Volume of Fluid)

A typical surface capturing method

Interface approximated by piecewise interpolation from cell volume fraction

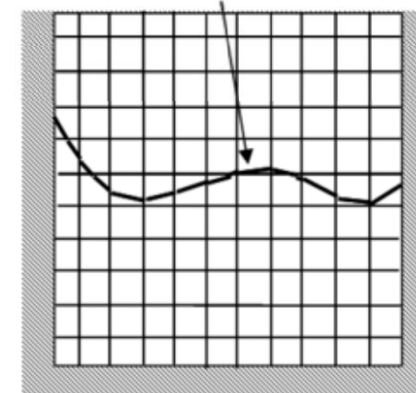

(a) Volume of Fluid model

Available From 6<sup>th</sup> OpenFOAM Workshop (Maki, 2011) 4

## Flow Chart (OpenFOAM)

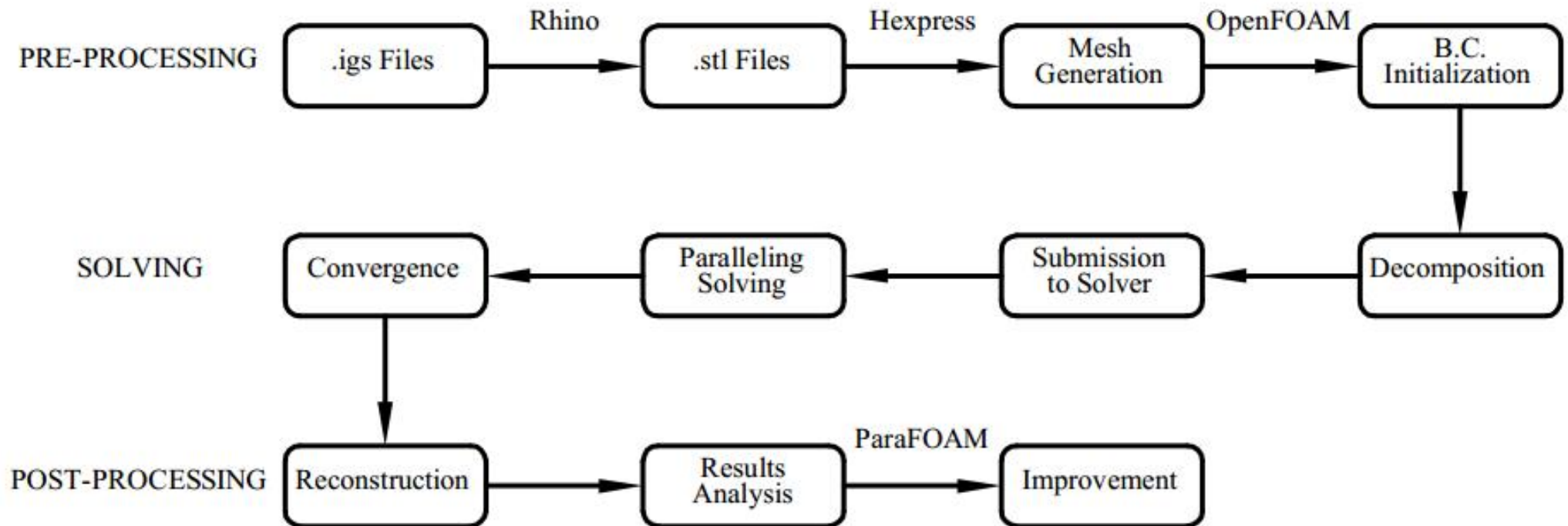

## 1. Model (KVLCC2)

1. Geometry: *igs* file from <http://www.simman2008.dk>
2. Computational Domain

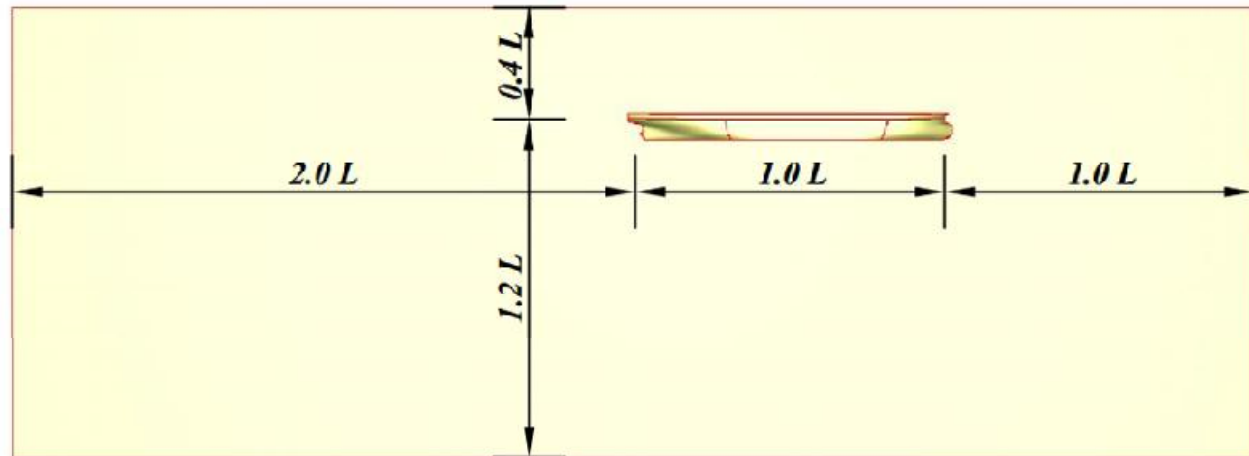
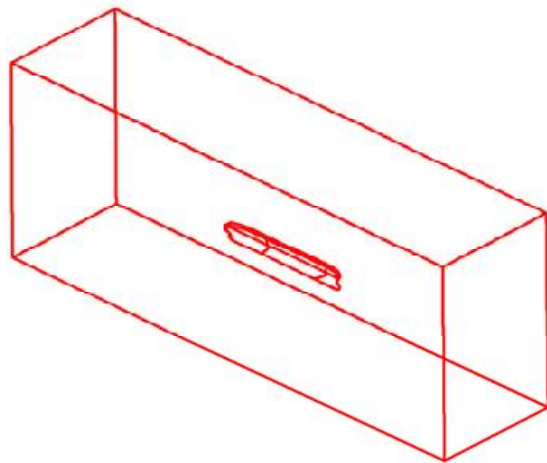

3. Boundary Conditions

7 Patches: in, out, top, bottom, farps, sym, ship

## 2. Mesh (KVLCC2)

Numeca Hexpress

1. Initial Mesh
2. Adapt to Geometry
3. Snap to Geometry
4. Optimize
5. Viscous Layers

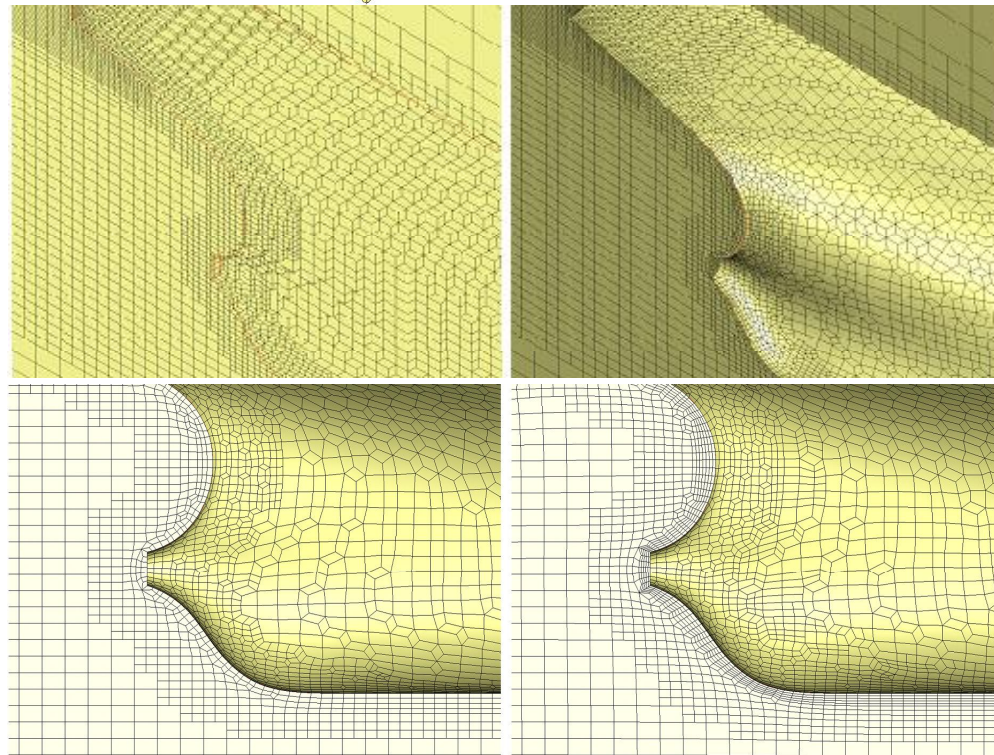
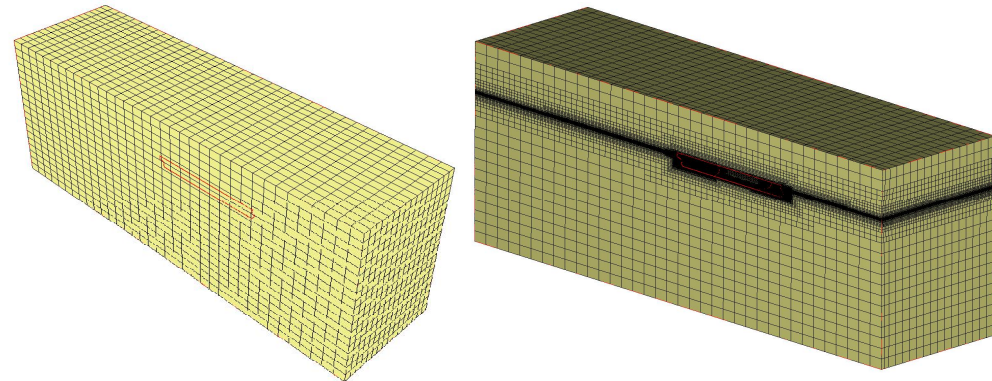

### 3. OpenFOAM Files

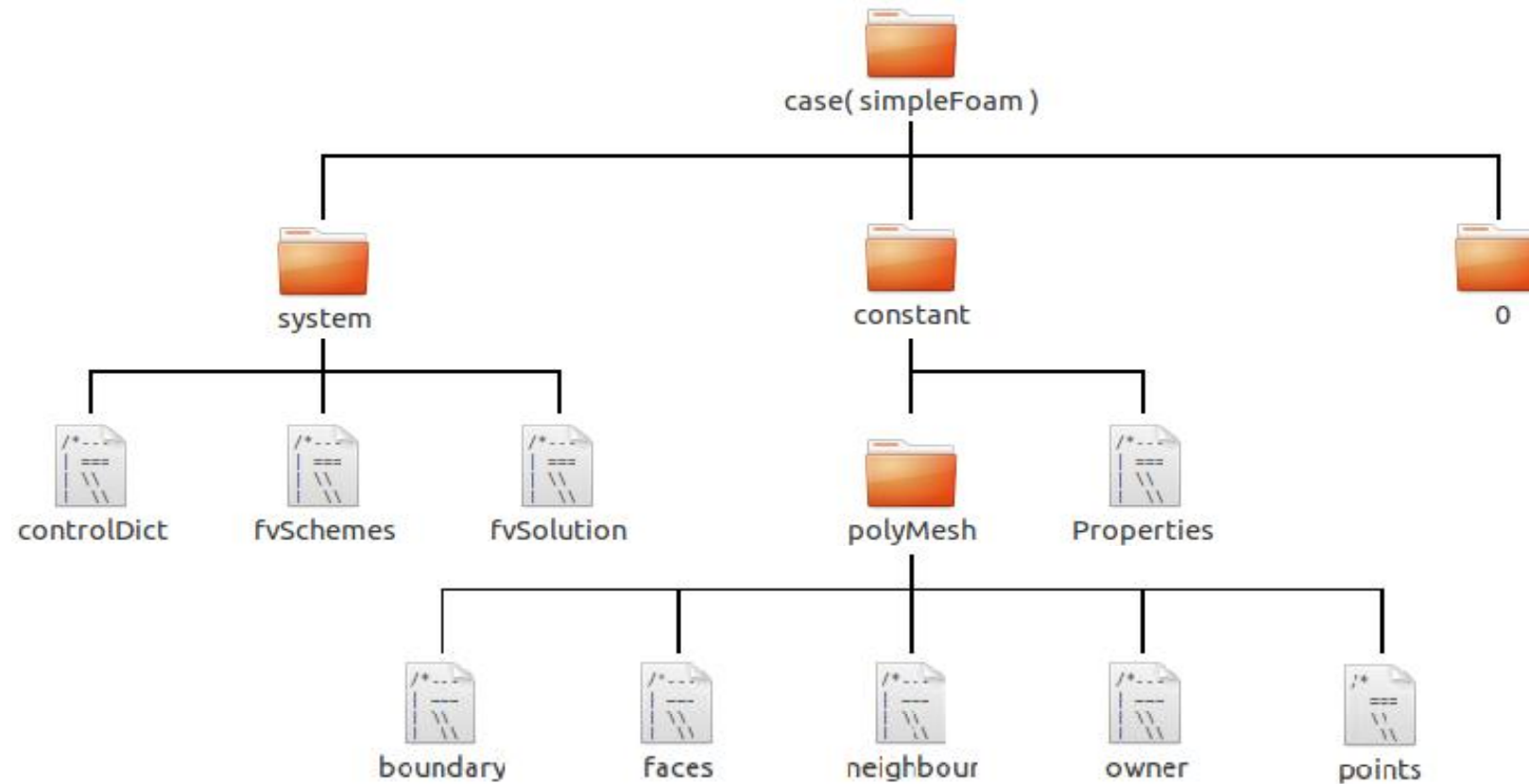



## 4. Adjustments

### A. Determination of Turbulence Intensity

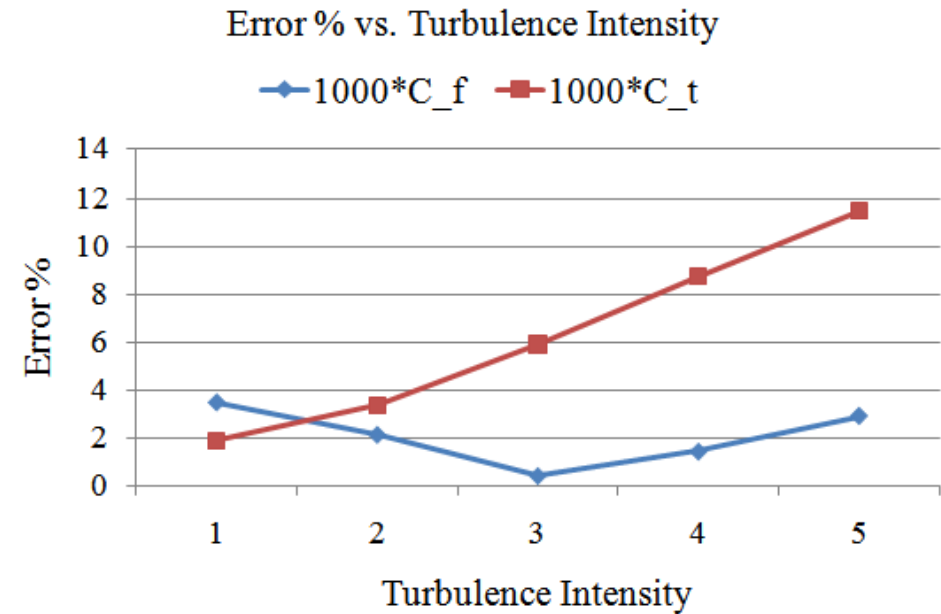

### B. Local Box Refinement

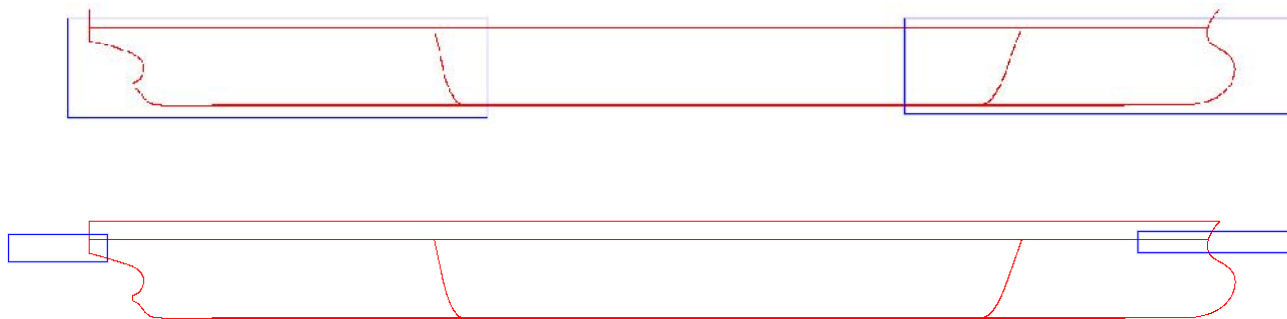

## 4. Adjustments

### C. Discretization of Free Surface

Longitudinal: 0.08 m  
 Transversal: 0.06 m  
 Vertical: 0.004 m

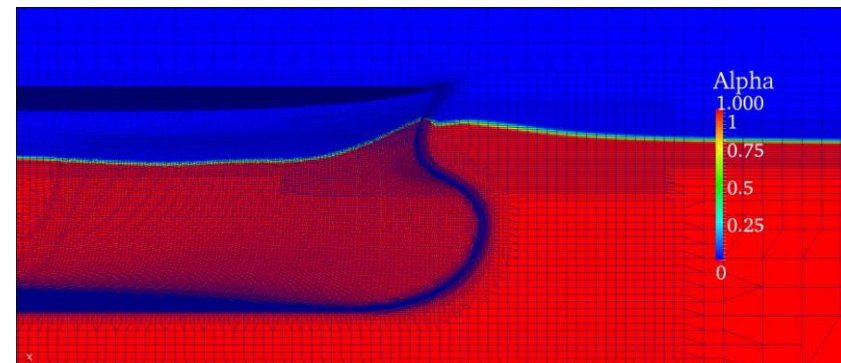
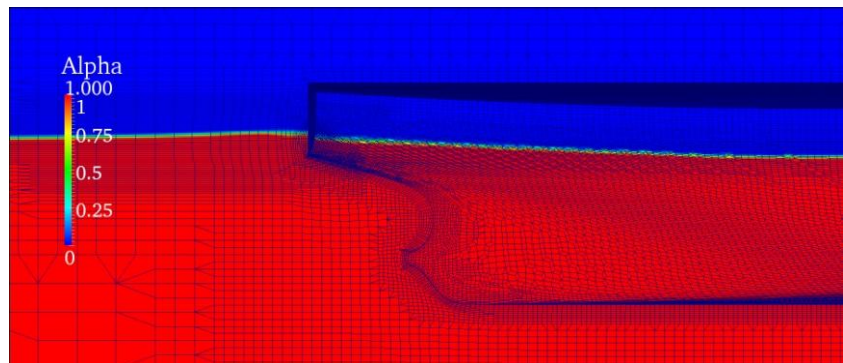
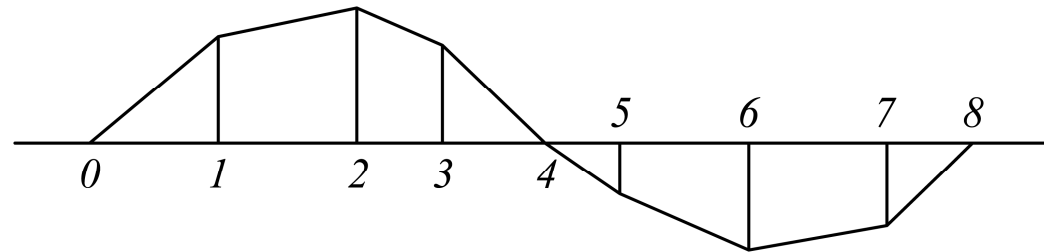

## 1. Iteration Convergence

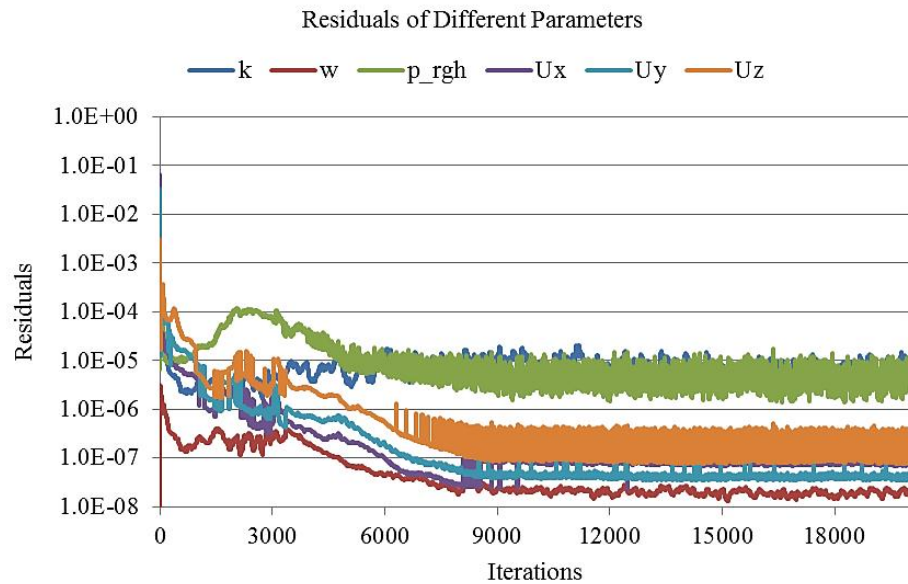

Parameter Residuals

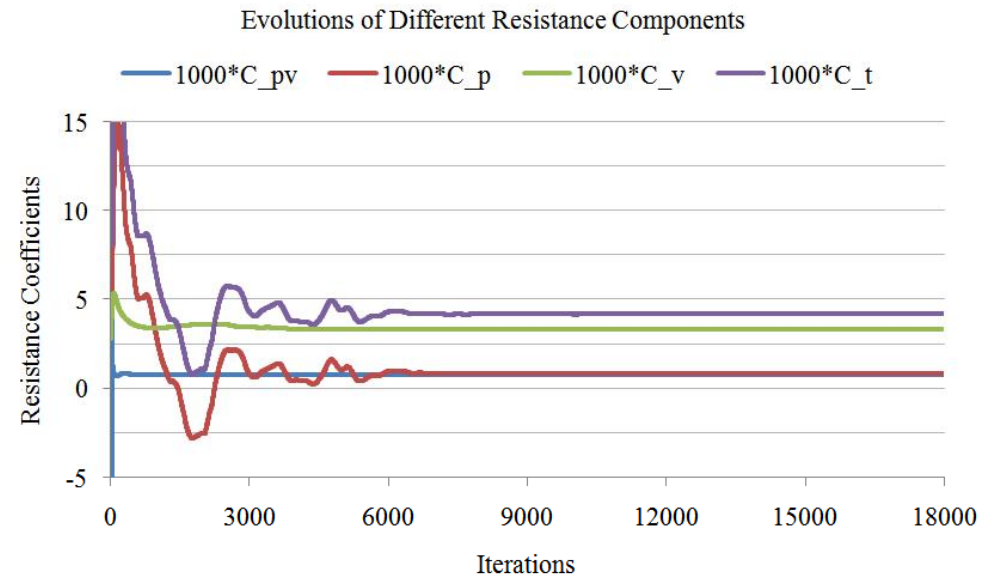

Resistance Coefficients

## 2. Post-processing (paraFoam)

Velocity  
Magnitude

$$U_{in} = 1.047 \text{ m/s}$$

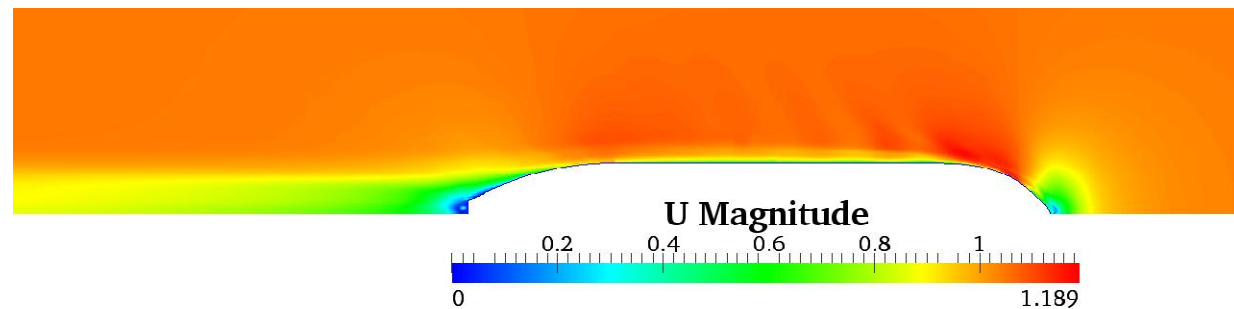

Pressure  
Distribution

$$P = \frac{1}{2} \rho U_{in}^2 = 548.1 \text{ N/m}^2$$

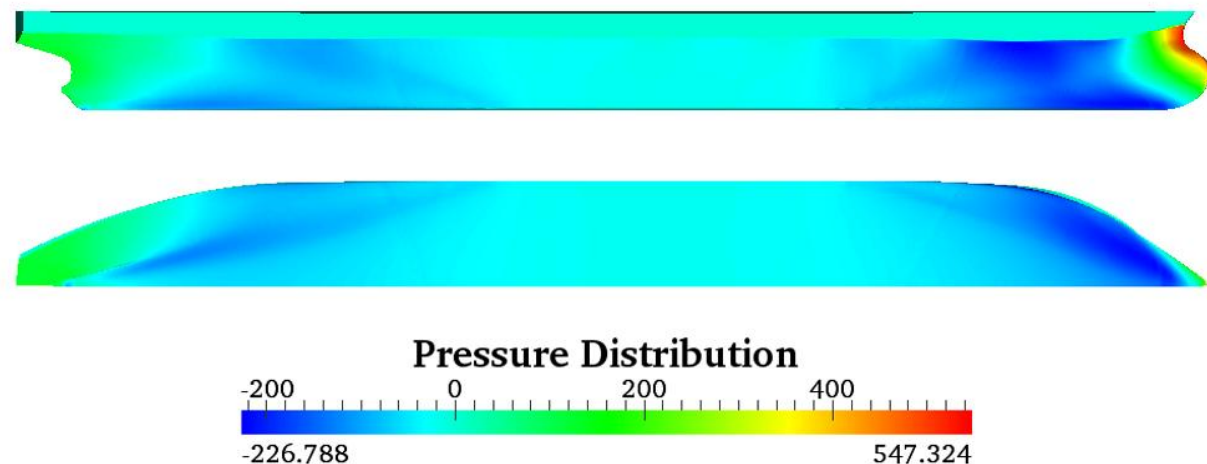

## 3. Grid Convergence

	initial mesh			cell No. (million)
	x	y	z	
Level 1	23	10	12	1.67
Level 2	36	16	19	2.65
Level 3	40	18	21	3.44
Level 4	45	20	23	4.27
Level 5	51	23	26	4.91

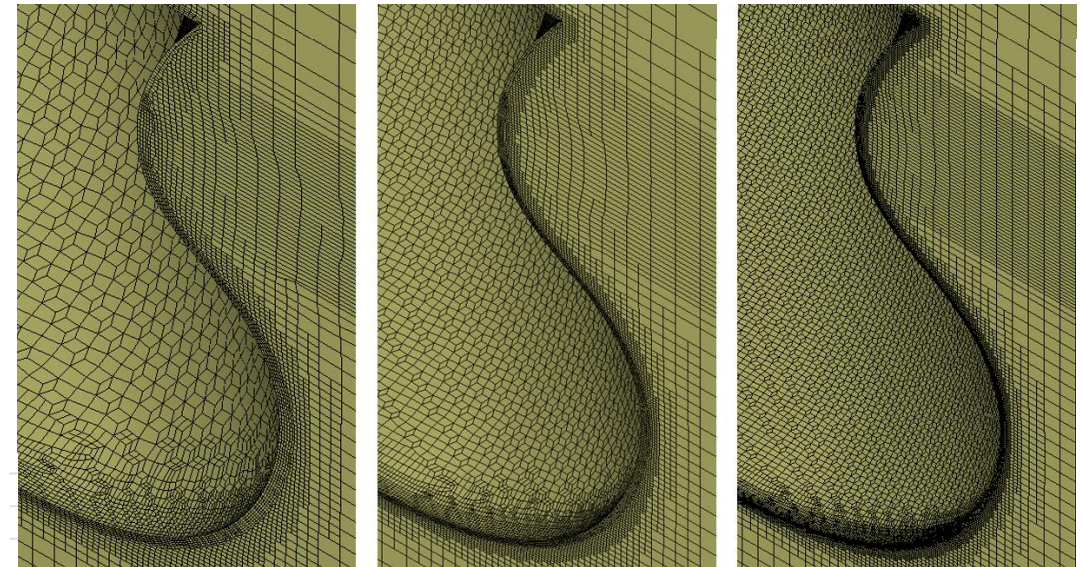

Level 1

Level 3

Level 5

← Error% of Total Resistance

CFD:  $1+k = 1.187$

EFD:  $1+k = 1.191$

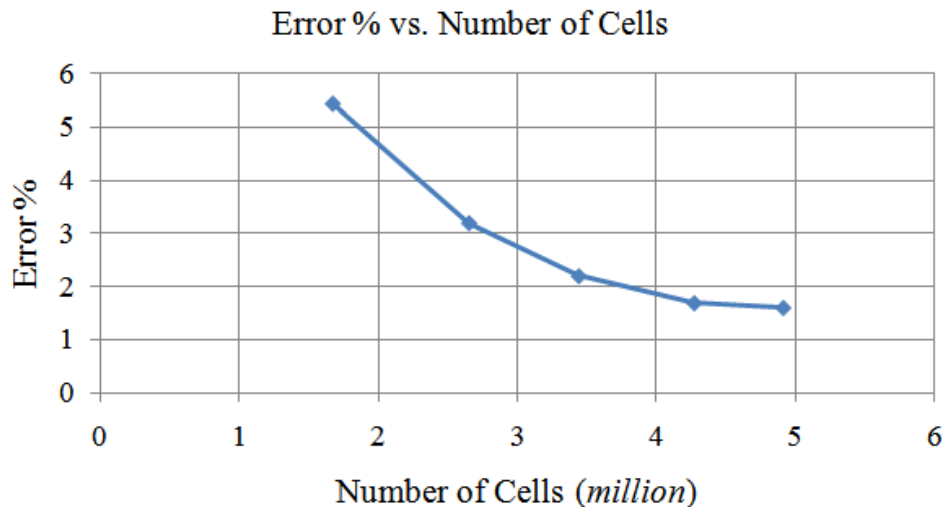

## 4. Wave Elevation

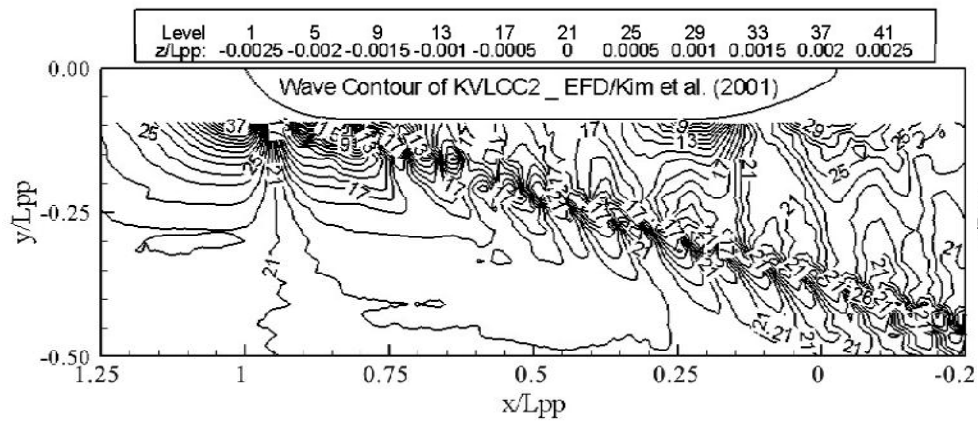

Wave Cut at  $y/L_{pp}=0.0964$

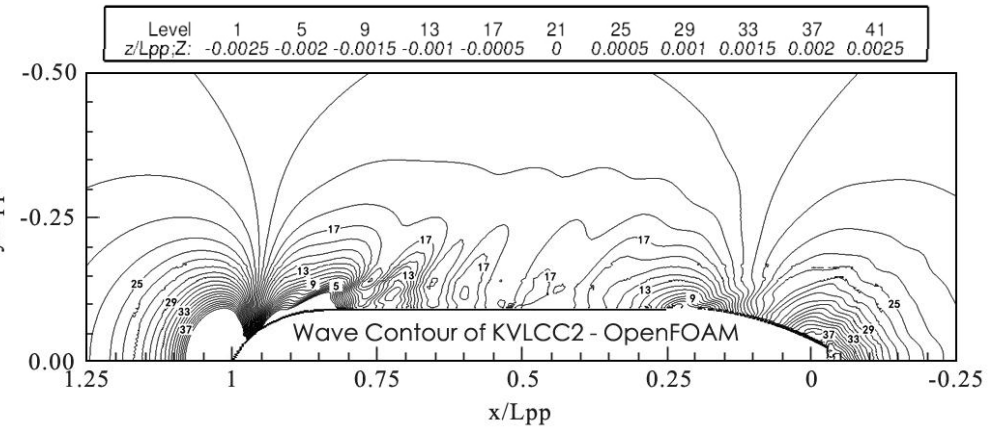
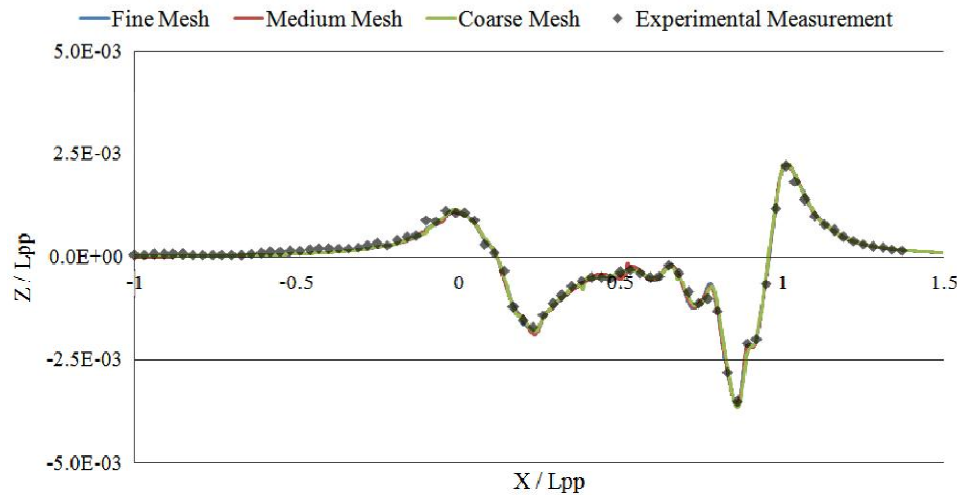

Wave Cut at  $y/L_{pp}=0.2993$

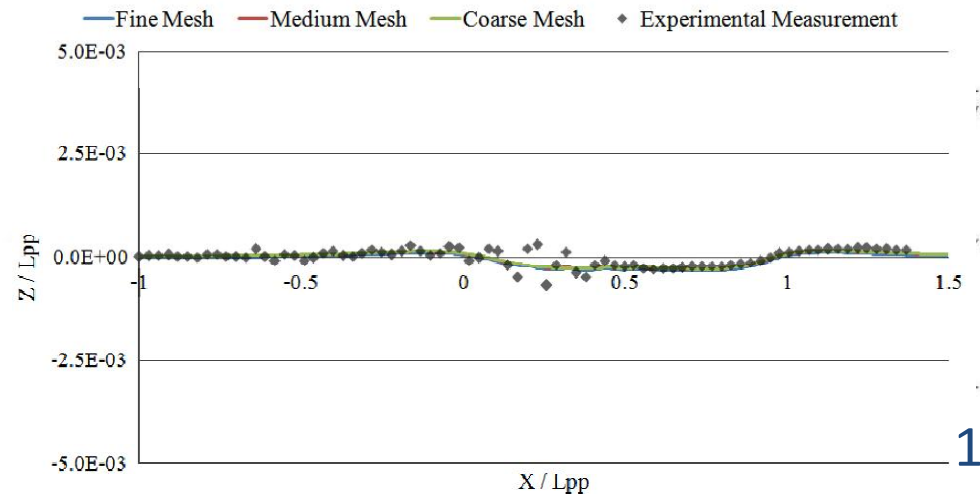

## Model Scale

1. KVLCC2 to JBC : Reynolds Number Similarity

$$Re = \frac{U_{KVLCC2} L_{KVLCC2}}{\nu_{KVLCC2}} = \frac{U_{JBC} L_{JBC}}{\nu_{JBC}}$$

2. Full Scale to Model Scale : Froude Number Similarity

$$Fr = \frac{U_{ship}}{\sqrt{gL_{ship}}} = \frac{U_{model}}{\sqrt{gL_{model}}}$$

Model Scale of JBC Bulker:  $\lambda = 1:55.1$

## Calculated Results

	minimal target size (m)			cell No. (FSM) (million)	cell No. (DBM) (million)
	x	y	z		
coarse	0.064	0.050	0.003	2.69	0.96
medium				3.28	1.20
fine				4.24	1.56

\*FSM is for free surface model and DBM is for double body model

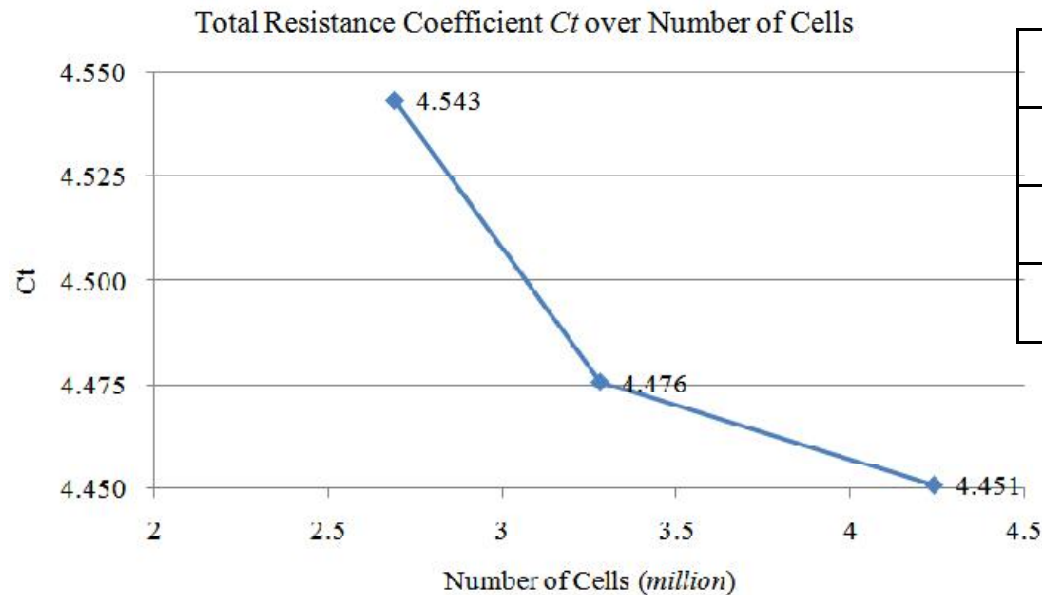

Parameters		EFD (D)
$C_T \times 10^3$	Value	<b>4.29</b>
sinkage [%LPP]	Value	<b>-0.086</b>
trim [%LPP]	Value	<b>-0.180</b>

$$\text{Error}\%C_t = \frac{(C_{t\_CFD} - C_{t\_EFD})}{C_{t\_EFD}} \times 100\% = 4.3\%$$



## Wave Elevation

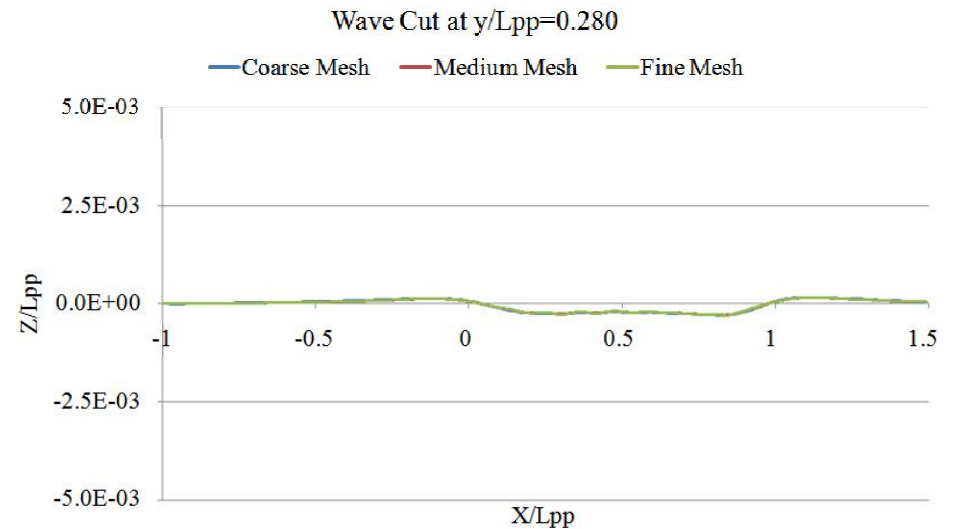
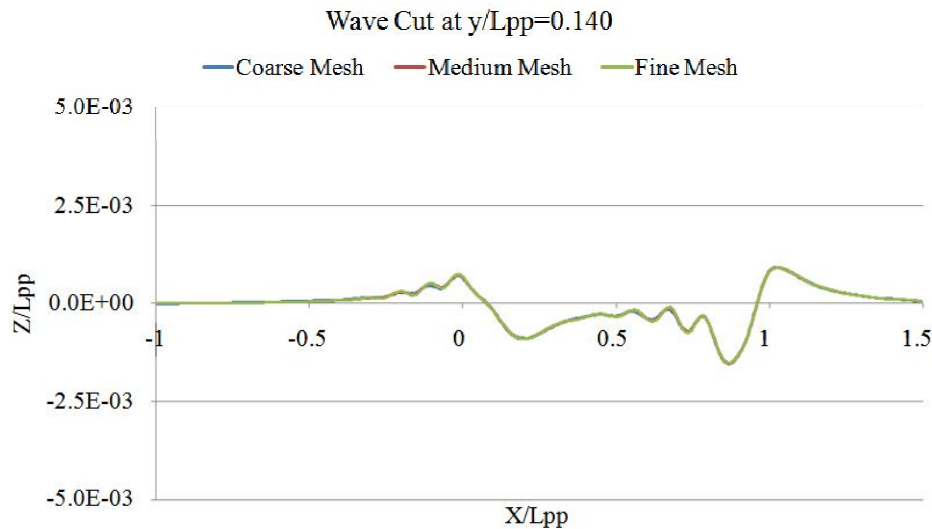
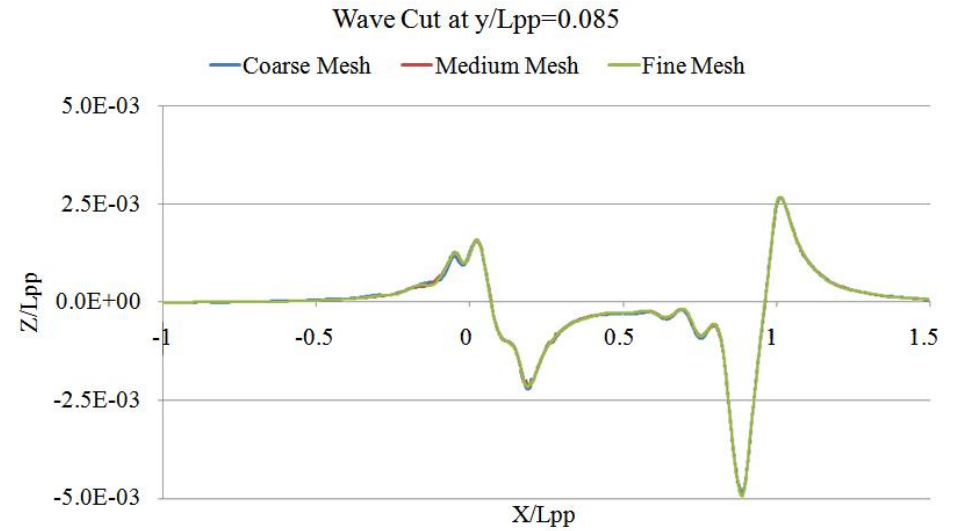
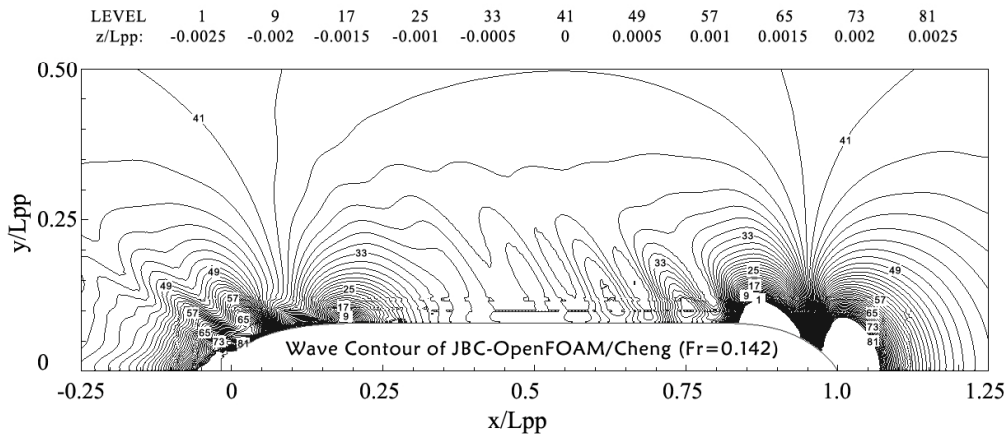

1. The Mesh Configuration obtained from Hexpress is Reliable.
2. The CFD Method to Predict the Resistance Components by OpenFOAM solvers is feasible. The Calculated Results are Acceptable.
3. Type of Turbulence Model and Parameters in OpenFOAM Files are Important.